

For cross steering applications

Model 'A' - 3Z

401 Legend Lane • Peculiar, MO 64078

Tech Line (816) 758-4504

800-334-7240

Fax (816) 758-4512

DRILL OUT THREADED HOLE
 IN BOX TO 7/16"!

WELD GUSSET TO BACK
 OF PLATE AND BOTTOM
 OF FRAME!

WELD ALL AROUND PLATE
 AND GUSSET ON THE BACKSIDE!

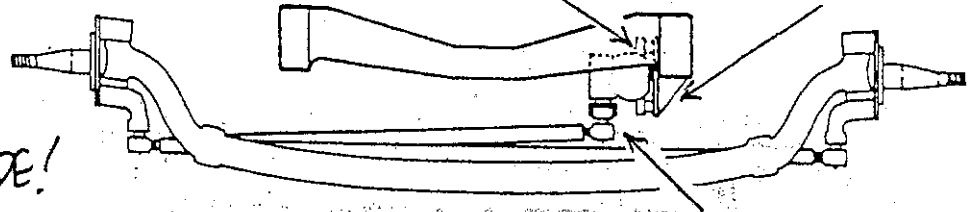

DRAG LINK IS 1/2" TO 1" HIGHER
 AT THIS END WITH CHASSIS AT
 RIDE HEIGHT!

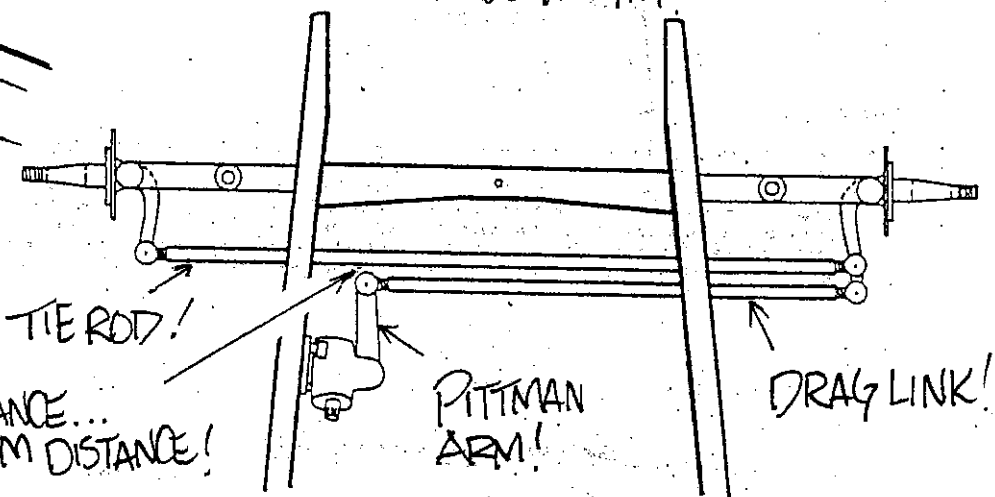
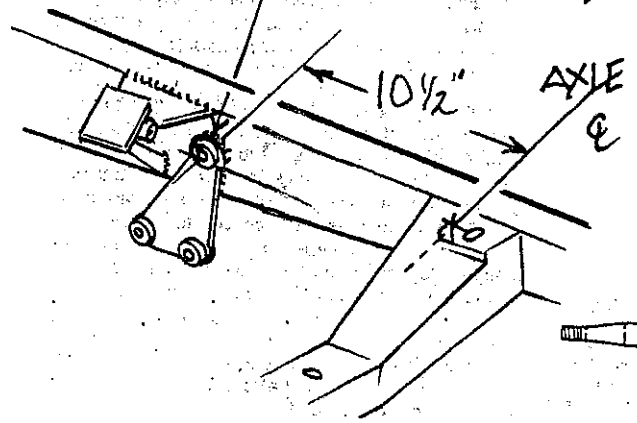

1/2" MINIMUM CLEARANCE...
 ... 6 1/2" MAXIMUM DISTANCE!

- 1) Remove stock pitman arm from steering box. Drill out top threaded mounting hole in box to 7/16".
- 2) Install Pete & Jake's Vega pitman arm #1020 on steering box and bolt the box to the plate. Make sure that the top mounting bolt (with lock washer) threads into the plate at least 1/2", but stops at least 1/16" from being flush with back side of plate.
- 3) Place the box and plate assembly on the inside of the boxed frame rail in a position that suits your installation the best. The box and U-joint must clear the motor mounts, exhaust system, engine and/or accessories that may be close to the steering box area. The box can mount behind or in front of the motor mounts as needed to clear the items mentioned, so long as the distance between the drag link rod end (on the pitman arm) and the tie rod is from 1/2" minimum to 6-1/2" maximum.
- 4) Viewing the chassis from the front, the drag link end on the pitman arm should be approximately 1/2" to 1" higher than the end on the spindle. This should be set when chassis is at ride height position. Heating and bending the pitman arm may be necessary to dial this in. NOTE: Heating and bending the pitman arm should be done with the end you are bending, splined or tapered, secured in a large vise to avoid distorting the hole. DO NOT heat/bend arm while attached to steering box.
- 5) Cars using cross steering, such as this Vega installation, require a panhard rod to control lateral movement of the front axle (see reverse side of this paper for full explanation). A front panhard rod kit is available from Pete & Jake's, part #1016.

STEERING U-JOINTS Steering U-joints are available as part no. 1018N. You will want to use a Vega steering shaft which has a 5/8"-36 spline end, and is available in three different lengths: 10" (#1035A), 12" (1035B), and 14" (1035C). The Vega steering shaft is used in conjunction with the steering U-joints mentioned above.