

# '32-'34 FORD

REAR SPRING MOUNTING KIT  
USING POSIE #AJAONH SPRING

Tech Line (816) 758-4504

800-334-72240

Fax (816) 758-4512

Our rear end brackets are designed for a 360-degree weld, that is a weld all the way around the housing. The idea of this is partially for strength but primarily so that warpage caused by welding will be equal around the housing, thus not pulling the housing out of shape as in the case where brackets are attached to the front and/or rear of the housing. Illustration (A) visually exaggerates what really happens to a housing. Needless to say, wheel bearings and carrier parts don't last. In our shop we remove the ends of the housing in a lathe and slide the brackets on. The ends are welded back on after all other welding on the housing is finished. You can achieve the same thing by cutting the ring part of the brackets in half (illustration B) and putting them on from both sides, then weld the brackets back together and then weld them 360-degrees to the housing. The results are well worth the effort.

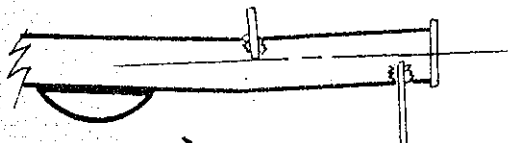

(ILLUSTRATION-A) WARPAGE CAUSED BY WELDING ON ONE SIDE OF HOUSING!

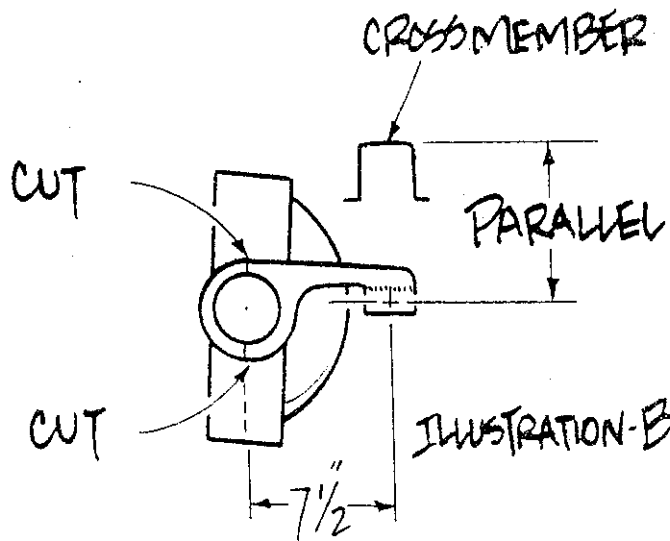

The spring hangers are relative to the spring, and the spring is relative to the crossmember. To avoid binding the spring and/or spring shackles, mount the spring hangers with the tube parallel to the top surface of the crossmember after pinion angle is set.

