

Instructions for #6012 - #6013
'42-'48 FORD

COIL OVER REAR SUSPENSION KIT

FOR USE WITH VIPER ALLOY
 COIL OVER SHOCK ABSORBERS

IMPORTANT NOTE: Remove the stock fuel tank from the car and put it in a safe place where sparks caused by the cutting torch cannot get to it. Removing the tank is also necessary to provide working room under the car.

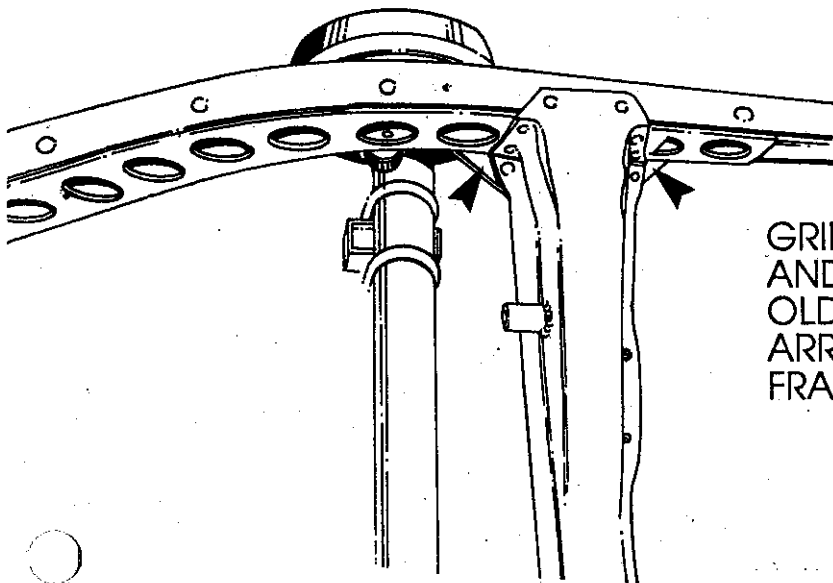

GRIND OFF RIVET HEADS (8 PER SIDE) AND PUNCH RIVETS OUT TO REMOVE OLD CROSSMEMBER. LOWER LIP (SEE ARROW) MUST BE CUT OFF FLUSH WITH FRAME TO WELD ON NEW CROSSMEMBER

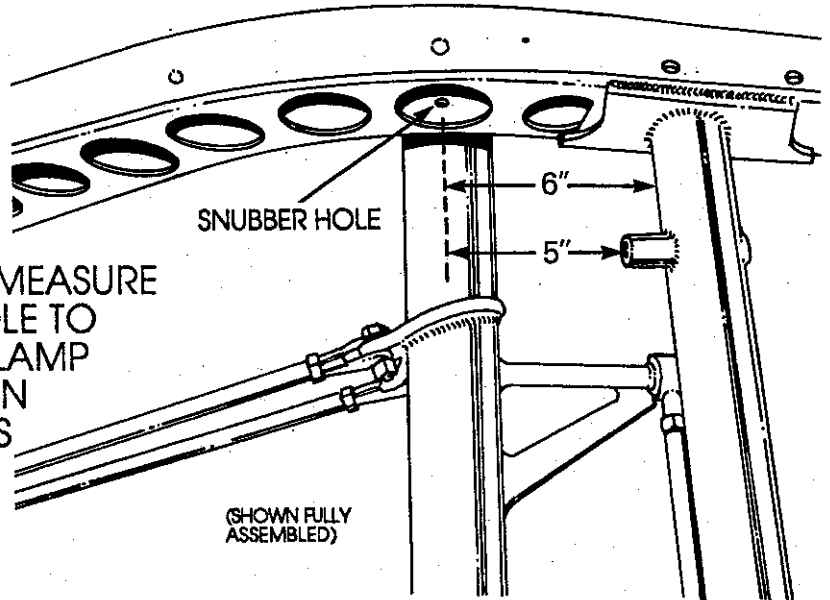

TO LOCATE NEW CROSSMEMBER, MEASURE 5" BACK FROM REAR SNUBBER HOLE TO FACE OF CROSSMEMBER TUBE. CLAMP AND TACK WELD INTO PLACE. THEN WELD TOP AND BOTTOM FLANGES ON EACH SIDE

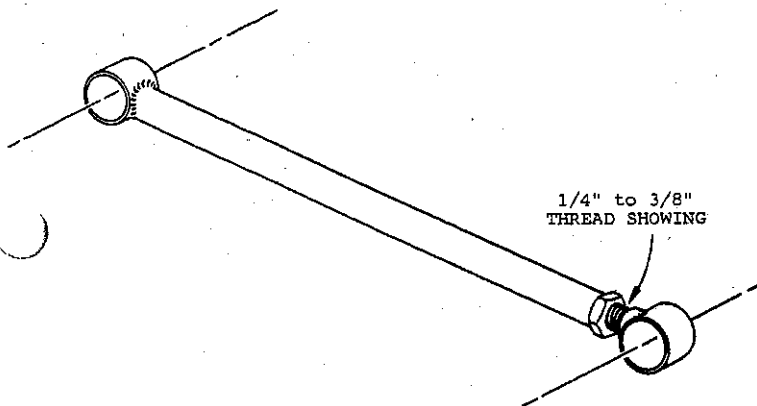

ASSEMBLE PANHARD BAR AND ADJUSTABLE END WITH 1/4" TO 3/8" OF THREAD SHOWING BEYOND JAM NUT. LAY ASSEMBLED BAR ON A FLAT SURFACE SO BUSHING CENTERLINES ARE PARALLEL, AND TIGHTEN THE JAM NUT.

(OVER)